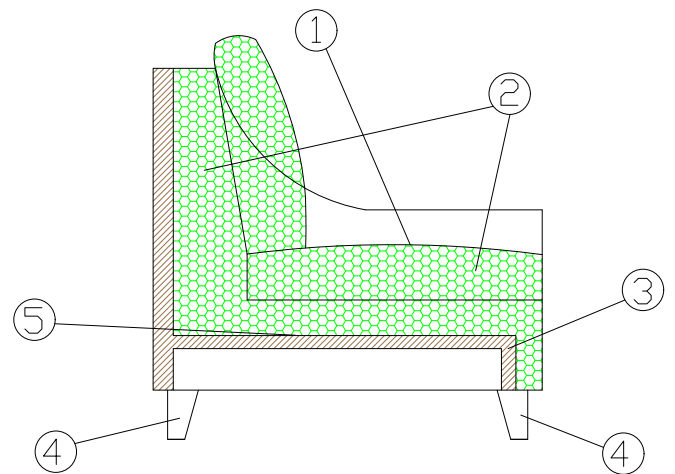
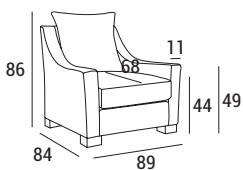
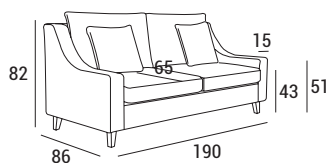
**ST53:**

- 1 - dacron® fiber 100 gr;
- 2 - high resilience polyurethane foam of different densities;
- 3 - structural frame in plywood, non-structural parts in composite wood;
- 4 - stained massive wooden feet;
- 5 - elastic webbing.

**ST108:**

- 1 - dacron® fiber 100 gr;
- 2 - high resilience polyurethane foam of different densities;
- 3 - structural frame in plywood, non-structural parts in composite wood;
- 4 - stained massive wooden feet;
- 5 - elastic webbing.

DIMENSIONS:**ST53****ST108**

1IM

ST53 - ST108

FEET:

ST53 h 4,5

ST108 h 11



WOODEN FEET FINISHINGS:



TECHNICAL DETAILS:

Removable cover: PARTIALLY	kg	m ³	mts
ST53	28	0.64	6.00
ST108	55	1.34	11.00

PHOTO GALLERY:



ST53



ST108

